



The Sculptors Society Bulletin

March - April 2005

ISSN 0728 1293

www.sculptorsociety.com

Sallie Portnoy has for the 2nd year in a row won the invitation only non acquisitive Yeramba Estates Sculpture Award of \$3500 at the Central Coast Festival of Arts, which runs from March 11 – March 20 in Wyong, with her elegant glass piece 'Two Blades'.

The exhibition was opened by Governor of NSW Her Excellency Professor Marie Bashir AC. This year the festival is celebrating its 30th year, and it was also voted the best regional art show in NSW.

James Deas was the adjudicator for the sculpture award. He has been a fine arts dealer for over 35 years & has been Curator & adviser to the William Bowmore Collection for 35 years. His status in the art world is acknowledged by his position as Government appointed Valuar/ Assessor for the commonwealth Taxation Incentive for The Arts scheme.

Award - congratulations!

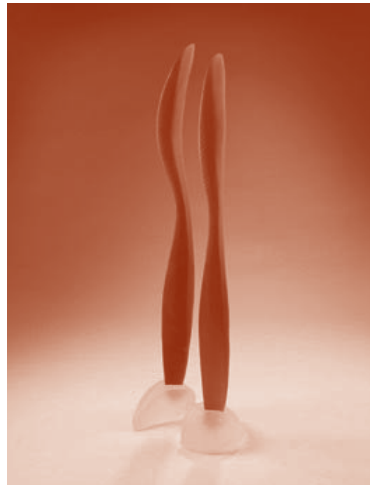

'Two Blades': In these pieces Portnoy is redefining the line while abstracting the form.

Her pieces are no longer figures or fish but capture the movement and sensuality of both. There is a metamorphosis going on which is clearly captured here. The glass plays with the light as it changes from thick to thin, as it absorbs and reflects the light, and as different colours mix when they are melted together.

Like the Sword in the Stone, the sword-like frond forms are plunged into their bases - grounded and earthbound, while their elegant forms reach up to the heavens, to a higher ground. The pieces are at once both male and female; at 'base' quite sexual and reflective of the basic nature of mankind. The figures speak of the conflict between opposing forces within us, between archaic impulses and new aspirations.

Our New President. Roger McFarlane's Message

It is a great honour to be elected President of The Sculptors Society. I am looking forward to a greater involvement with the sculptors in our society. I would like to congratulate Margaret Sheridan for the excellent work she has done as President. Margaret has worked hard and successfully as President to further the interests of the Society and its members. It will be a hard act to follow.

When I was asked to stand for the President's position, one of the things making the nomination easy to accept was the calibre of the members on the committee. They all put in a huge effort to make things happen with a minimum of fuss and in a spirit of co-operation. They are all to be congratulated for the work they have done, and I look forward to working with them.

The Society, established in 1951, is the oldest sculpture society in Australia. In 1952 Lyndon Dadswell described the aim of the society as "the advancement of the understanding and appreciation of sculpture and the widest use and application of sculpture and its associated arts." These are still the

guiding influences of the Sculptors Society today. This is expressed in our current Statement of Purpose:

- To actively promote sculpture to the widest possible audience
- To actively promote the work of all member sculptors
- To provide a forum to disseminate information regarding sculpture and sculptors
- To hold regular exhibitions.

We live in a time when society does not join groups, but concentrates on individual achievement. To ensure that we continue to be relevant for the next 55 years is one of the challenges we need to address.

Each new president brings a different style and adds a new layer to the long history of the Society. I believe that I am the first President of the Society to come from outside the Sydney metropolitan area. With this in mind I bring a different perspective to the job.

I work on the basis of "If it's not broke don't fix it". I do not believe in making change for change's sake. What I

would like to achieve during my presidency is to build on our strengths, and make The Society more inclusive of country members and less Sydney-centric. This does not mean reducing what we do in Sydney, but creating more opportunities for country members. To this end I invite all members both city and country to supply input to the committee so as to improve the value of their membership. Being proactive strengthens the society so that it is in tune with and relevant to its membership.

I would like to see more members attending the Forums. The Forums not only have interesting speakers, but give members the opportunity to network with other members and to speak directly to myself and the members of the committee in a relaxed and informal atmosphere.

To conclude, I feel honoured to be elected President of the Sculptors Society. I will do my best to ensure that our membership continues to grow. I will also work towards making sure that membership of The Sculptors Society is rewarding on many levels.

ANNUAL GENERAL MEETING - 3 MARCH 2005

We had a well attended AGM with lots of food, wine and time for chatting and catching up with friends before, during and after the formal part of the evening. There were many new faces too, which was good to see.

There was an election of office bearers for 2005, and the full list is on the back page of the Bulletin. Our beloved honorary treasurer Adrian Walker has resigned, but he's left us in good nick and in good hands, with a promise too to stick around while our new treasurer, member Feisal Ramadan settles into the role. A presentation of one of Jack Solar's lovely sculptures was made to him to thank him for his years of outstanding guidance. His abbreviated report follows.

Margaret Sheridan thanked the hard working Committee for their continuing good-natured and dedicated contributions. She summed up the years of her presidency and talked about our many achievements, as well as highlighting what we could do better. She is taking on a special role with regard to the improvement of our site and the show we put on at Sydney in Bloom in the Domain in September. She urged us to continue to present our work well, with regard to its presentation on good plinths!

Roger McFarlane addressed us in his new role as President, and also gave us a fascinating and polished presentation on his trip to Brazil.

HON. TREASURER'S REPORT:

Alan Mountfield of Sherley and Sherley, Chartered Accountants completed the audit of the Sculptors Society's financial statements and in his opinion, the balance sheet and profit and loss statements present fairly the financial position of The Sculptors Society and the result of its operations for the year ended 31 December 2004 are in accordance with the Australian Accounting Standards.

By way of summary the Society finished the year with an operating surplus. The Sculptors Society has had another good year and is in a strong financial position. The major source of income was membership subscriptions and commission received on sculpture sales.

Commission received this year was down due to less sales. It has been a tough year and although I'm not a forecaster, 2005 will similarly be a year full of challenges.

On the expenditure side of the ledger, your Committee has continued to maintain tight control which has resulted in the earlier mentioned surplus being achieved.

When considering the results, membership, exhibitions and exhibition sales are the key, and in 2004 your committee under

Margaret's leadership performed well.

With the President's permission, I now put the motion that the accounts be accepted and the auditor, Alan Mountfield be re-appointed for the year ended 31 / 12 / 2005.

In conclusion, I mention that I will not be nominating for the position of Hon. Treasurer this year but know that the Society finances will be in very good hands. I thank you all for allowing me to be part of the Society's activities which I hope to be able to continue in the future.

STONE SCULPTORS

Workspace available, as well as stone-cutting, and shaping equipment. Shaping assistance, plinths, and installation by skilled stonemason. Yard at Elanora Heights.

Enquiries: Phone Damian on 0425 212 852 or email him at damiannonk@optusnet.com.au

Welcome

We warmly welcome 2 new full members: Gunnel Watkins and Efat Yahyaoglu.

LATHAM
design engineers & manufacturers

Latham Australia Pty Ltd
14 Tennyson Rd.
Gladesville, 2111
Ph: (02) 9879 7888
Fax: (02) 9879 7666
info@latham-australia.com

HAND CHISELS — 3 to 40mm

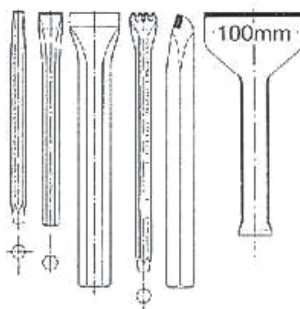

MACHINE TOOLS — 6 to 50mm

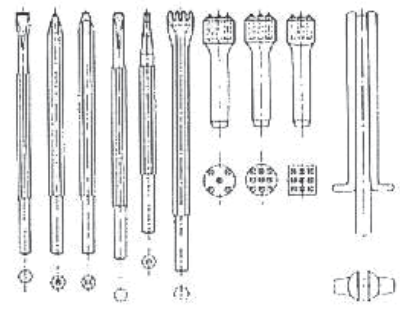

For over 30 Years Lathams have been supplying the stone industry, amateur and professional Stone Masons, Sculptors, Marble and Granite users.

Our range includes a comprehensive stock of Cuturi pneumatic hammers, hand and machine tungsten carbide chisels, nylon mallets, bitch picks, diamond core drills, diamond blades, grinding wheels and disks.

Sealers, polishers, waxes, cleaners, mastic and epoxy also in stock. Either drop into our showroom or contact us on the above numbers.

Our Society was well represented at the Royal Easter Show this year, and we had several prize winners.

Babette F. Gomme won the abstract sculpture prize, and Kay Alliband was 2nd in that section.



Babette Gomme with her winning Abstract Form. Red Cedar. Approx. 750mm cubed.



Bruce Nicholas: Thought in Form
Ilford Slate on black granite 300 x 300 x 150mm

Bruce Nicholas was 2nd in the Figurative section, and Ljubov Seidl was 3rd in the miniature section. Ljubov also won the Glass section, and Kay Alliband won the Ceramic section. The judge was David Handley who created and runs "Sculpture by the Sea".

The Art Preview evening on 16/3/05 was a very well attended and generously catered for evening. Babette gave a vote of thanks to Ana von Alten, who is the Art and Crafts co-ordinator, and presented her with flowers and bottles of "lolly water" from the exhibitors.

Royal Easter Show



Ljubov Seidl: Never ending story.
Glass. 300 x 300 x 150mm

Kay Alliband's *Fallen* is a sculpture she just had to do. She writes:

It's been brewing in me for many years – but the form it would take only came to me last year when I was working on my mosaic "Falling Runners", a series of carpets seemingly falling out of the sky.

My youngest brother Kevin Hitchcock broke his neck when he fell from a rope swinging over the Hawkesbury River. This fall changed not only his life, but that of everyone connected with him. After 10 years he mustered the strength to write a book, 'Walk with me', about the experience.

Before the accident he was a journalist and Director of Channel 10 TV news. After the accident, writing this book using a computer became a mammoth physical effort but he stuck with it and eventually succeeded.

I made "Fallen" from winterstone pressed into a mesh form. Initially I had it hanging from the ceiling of my studio.



Kay Alliband: *Fallen* (Detail)

On one side I have written the account of his fall from the start of chapter 1 of the book 'Silence. From the time I let go of the rope swinging above the muddy brown water of the Hawkesbury River'.....to.....'You should know that because of this damage you will be a quadriplegic for the rest of your life.'

The writing was applied whilst the medium was still damp – fresco technique. This was the only way I could work out how to do it, i.e. to include the writing on a folded form. Once writing was on the damp winterstone I folded that section of the form, wired it together and moved on to the next section. It was a very time consuming piece but I just had to do it.

Wanted

Like-minded sculptor or artist wanted to share work space. Possible to live-in, if suitable.

Quiet beaches area, mid - North Coast. 2-story studio home.

Phone Carol on phone: 02 655 44322 or on her mobile: 0414 98 20 20.

Plinths + Marble

Any member who needs a metal plinth or slabs of marble in varying sizes and colours, should ring Babette on 9486 3438, to arrange a time to inspect.

All are very reasonably priced.

The proceeds will go to a sculpture award donated by our member Jack Solar.

Wanted

Art Foundry assistant required

Duties will include all aspects of bronze process from mould making to patina. Good working conditions with flexible hours. Wages negotiable depending on level of skill.

Call Jody Pawley: 9181 4993
Sculpture Studio Gallery
Drummoyne



Tom Bass Sculpture Studio School

Head Study from life

Commencing Friday April 29th
10am to 1 pm for 10 weeks \$480

Drawing Class

Commencing Tuesday 10th May
6.30 to 9 pm for 6 weeks \$180

Life Class

Commencing Tuesday 26th April
9.30 – 4.30 pm for 10 weeks \$780

April Holiday Intensive Program

Varied Program Commencing April 10th, through to April 19th

Enrol now for term 2:

Early Bird discounts

Term 2 starts Sat April 23rd

Flexible programs of workshop classes

Workshop classes: day, evening and Saturday classes

Visit our new website, or better still visit the school
or let us know how we can keep you informed.

1a Clara St Erskineville 2043 ph 02 9565 4851
tbsss@tpg.com.au www.tombasssculptureschool.org.au

May Forum - Thurs. 26 May 2005 7.30pm North Sydney Leagues Club

"Who is Aleksandra Kasuba? Come and find out for yourself. I can only say: she was a very well known sculptor in New York for 50 years. She now lives in the desert of New Mexico, constructing a group of dwellings of futuristic shapes." **Jolanta Janavicius** will show images supplied by Aleksandra, and talk about her work.

Sergio Redegalli, a glass sculptor will give us a talk on **"marketing your sculptures"**.

The Sculptors Society Bulletins provide information, and topical news and views considered to be of interest to our readers. Nothing written here is intended as a substitute for professional advice, and no liability arising from our publications is accepted. Articles and reviews submitted may be edited at the discretion of the editor, and no correspondence in this regard will be entered into.

President

Roger McFarlane
Ph: 0418 686 280, Fax: 4962 2608
P. O. Box 549, Newcastle, NSW 2300
tracksculpture@macmfg.com

Vice President,

Darling Park Co-ordinator

Babette Gomme
Ph: 9486-3438 Fax: 9450 1410
311 Weemala Rd, Terrey Hills, NSW 2084

Vice President,

Sydney in Bloom Co-ordinator

Margaret Sheridan Ph: 9405-5377 (H)
Ph: 9966-8411 (W); Fax: 9966-4377
Unit 11, 130-134 Pacific Highway,
St. Leonards, NSW 2065
margsheridan@optusnet.com.au

Bulletin Editor

Sally Zylberberg
Ph: 9909-1799, Fax: 9908-1275
zylberberg@bigpond.com
5 Bogota Ave, Cremorne, NSW 2090

Web, + Bulletin invoices

Christiane Conder Ph: 9958-1971
87 Baringa Rd, Northbridge, NSW 2063
cconder@bigpond.com

www.sculptorsociety.com

Treasurer

Feisal Ramadan Ph: 9945 0261
46 Koorngal Ave, Thornleigh, 2120

Secretary - Membership

Eva Chant Ph: 9481 9060
Mobile: 0418 250 456
10 Corang Rd, Westleigh, NSW 2120
echant@bigpond.net.au

Secretary - Minutes

Sandra Hoey-Stone Ph: 9977-6625
sstone1@optusnet.com.au

Publicity Officer

Karin Krueger
KDK Media
Ph: 9979 3718
P.O.Box 218, Church Point, NSW 2105

Committee without portfolio

Gary Grant
Jolanta Janavicius Ph: 9939 2180
Ella Krug Ph: 9417 4718
David Solomon Ph: 9360 2182
Henri Teris Ph: 9362 9889